

Guillaume Tell

Overture

4 Trumpets or Cornets

Arr.: Dennis Armitage / Jirka Kadlec

Gioachino Rossini

EMR 91641

1. Trumpet or Cornet B^b + E^b
2. Trumpet or Cornet B^b
3. Trumpet or Cornet B^b
4. Trumpet or Cornet B^b

Score / Partitur / Direction

Des milliers d'enregistrements disponibles sur
Thousands of recordings available on
Tausende Aufnahmen verfügbar unter



TÉLÉCHARGEMENT : UN CLIC, UNE IMPRESSION – À VOUS DE JOUER !

Achetez, imprimez et jouez vos partitions en toute simplicité.

DOWNLOADING: ONE CLICK, ONE PRINT – AND YOU'RE READY TO PLAY!

Buy, print and play your sheet music with ease.

DOWNLOAD: EIN KLICK, EIN AUSDRUCK – UND SCHON KANN'S LOSGEHEN!

Kaufen, drucken und spielen Sie Ihre Noten ganz einfach.

WWW.REIFT.CH



EDITIONS MARC REIFT

Route du Golf 150 • CH-3963 Crans-Montana (Switzerland)
Tel. +41 (0) 27 483 12 00 • E-Mail : info@reift.ch • www.reift.ch

Guillaume Tell

Gioachino Rossini (Arr.: Dennis Armitage / Jirka Kadlec)

Français:

La **Guillaume Tell Overture**, composée par **Gioachino Rossini** en 1829, est l'un des morceaux les plus emblématiques du répertoire classique. Cette ouverture, initialement destinée à l'opéra du même nom, se distingue par sa structure en plusieurs sections contrastées, allant de passages doux et lyriques à des rythmes énergiques et fulgurants. Elle illustre parfaitement le génie de Rossini pour la couleur orchestrale et le dynamisme musical.

L'œuvre raconte, à travers la musique seule, des scènes dramatiques et héroïques inspirées de la légende de Guillaume Tell. Sa dernière section, célèbre pour son rythme trépidant et ses accents triomphants, symbolise la victoire et la liberté. L'ouverture a traversé les époques et reste un incontournable de la culture musicale mondiale, inspirant films, publicités et adaptations contemporaines.

Dans cet arrangement signé Dennis Armitage et Jirka Kadlec, l'esprit et l'énergie de Rossini sont conservés tout en offrant une version accessible et vivante, capable de captiver tout type de public. Cette réinterprétation moderne permet de redécouvrir les subtilités et la virtuosité de cette œuvre légendaire.

English:

The **Guillaume Tell Overture**, composed by **Gioachino Rossini** in 1829, is one of the most iconic pieces of classical music. Originally written for the opera of the same name, this overture is remarkable for its multi-section structure, ranging from gentle, lyrical passages to energetic and thrilling rhythms. It perfectly showcases Rossini's genius for orchestral color and musical dynamism.

The work tells, through music alone, dramatic and heroic scenes inspired by the legend of Guillaume Tell. Its final section, famous for its galloping rhythm and triumphant accents, symbolizes victory and freedom. The overture has endured through the ages and remains a cornerstone of world musical culture, inspiring films, advertisements, and contemporary adaptations.

In this arrangement by Dennis Armitage and Jirka Kadlec, the spirit and energy of Rossini are preserved while offering an accessible and lively version, capable of captivating any audience. This modern reinterpretation allows listeners to rediscover the subtleties and virtuosity of this legendary work.

Deutsch:

Die **Guillaume Tell Ouvertüre**, komponiert von **Gioachino Rossini** im Jahr 1829, gehört zu den bekanntesten Werken der klassischen Musik. Ursprünglich für die gleichnamige Oper geschrieben, zeichnet sich diese Ouvertüre durch ihre mehrteilige Struktur aus, die von sanften, lyrischen Passagen bis zu energiegeladenen und mitreißenden Rhythmen reicht. Sie zeigt Rossinis Genie für orchestrale Farben und musikalische Dynamik.

Das Werk erzählt allein durch die Musik dramatische und heroische Szenen, inspiriert von der Legende des Wilhelm Tell. Der letzte Abschnitt, berühmt für seinen galoppierenden Rhythmus und triumphale Akzente, symbolisiert Sieg und Freiheit. Die Ouvertüre hat die Jahrhunderte überdauert und bleibt ein Eckpfeiler der weltweiten Musikkultur, der Filme, Werbung und zeitgenössische Adaptionen inspiriert.

In dieser Bearbeitung von Dennis Armitage und Jirka Kadlec wird der Geist und die Energie Rossinis bewahrt, während eine zugängliche und lebendige Version präsentiert wird, die jedes Publikum fesselt. Diese moderne Neuinterpretation ermöglicht es den Zuhörern, die Feinheiten und Virtuosität dieses legendären Werks neu zu entdecken.



EDITIONS MARC REIFT

Route du Golf 150 • CH-3963 Crans-Montana (Switzerland)

Tel. +41 (0) 27 483 12 00 • E-Mail : info@reift.ch • www.reift.ch



Guillaume Tell

Overture

Gioachino Rossini

Arr.: Dennis Armitage /

Jirka Kadlec

Andantino ♩ = 66

1. B♭ Trumpet
or Cornet

2. B♭ Trumpet
or Cornet

3. B♭ Trumpet
or Cornet

4. B♭ Trumpet
or Cornet

EMR 91641

© COPYRIGHT BY EDITIONS MARC REIFT CH-3963 CRANS-MONTANA (SWITZERLAND)
ALL RIGHTS RESERVED - INTERNATIONAL COPYRIGHT SECURED

www.reift.ch

C Allegro vivace ♩ = 152

50

Musical score for measures 50-59, featuring four staves (1-4) in 2/4 time. The music is marked *f* (forte) throughout. The first staff has a dynamic marking of *f* at measure 51. The second staff has a dynamic marking of *f* at measure 51. The third staff has a dynamic marking of *f* at measure 50. The fourth staff has a dynamic marking of *f* at measure 50.

D

60

Musical score for measures 60-68, featuring four staves (1-4) in 2/4 time. The music is marked *mf cresc.* (mezzo-forte crescendo) from measure 60 to 64, then *sf* (sforzando) from measure 65 to 66, and *p* (piano) from measure 67 to 68. The first staff has dynamic markings of *mf cresc.*, *sf*, and *p*. The second staff has dynamic markings of *mf cresc.*, *sf*, and *p*. The third staff has dynamic markings of *mf cresc.*, *sf*, and *p*. The fourth staff has dynamic markings of *mf cresc.*, *sf*, and *p*.

69

Musical score for measures 69-76, featuring four staves (1-4) in 2/4 time. The music is marked *f* (forte) from measure 69 to 72, and *p* (piano) from measure 73 to 76. The first staff has dynamic markings of *f* and *p*. The second staff has dynamic markings of *f* and *p*. The third staff has dynamic markings of *f* and *p*. The fourth staff has dynamic markings of *f* and *p*.

E

77

Musical score for measures 77-84, featuring four staves (1-4) in 2/4 time. The music is marked *f* (forte) throughout. The first staff has dynamic markings of *f* at measure 77 and *f* at measure 80. The second staff has dynamic markings of *f* at measure 77 and *f* at measure 80. The third staff has dynamic markings of *f* at measure 77 and *f* at measure 80. The fourth staff has dynamic markings of *f* at measure 77 and *f* at measure 80.

Collection Trumpet-Cornet

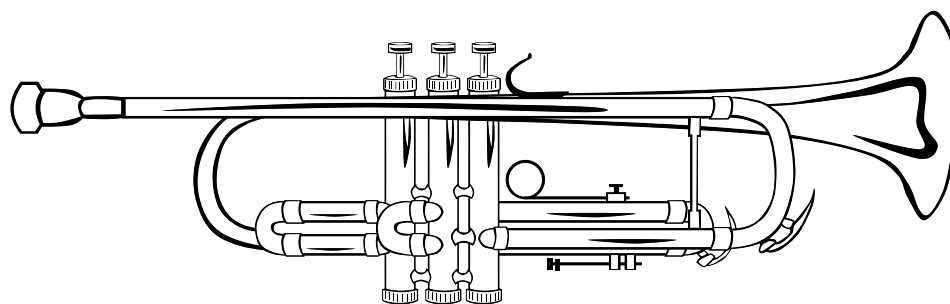
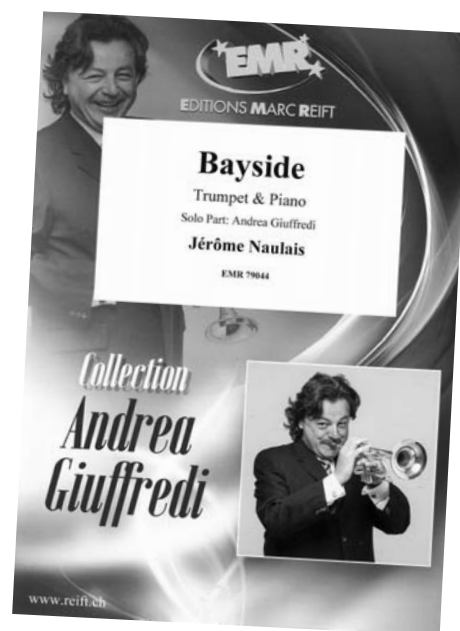
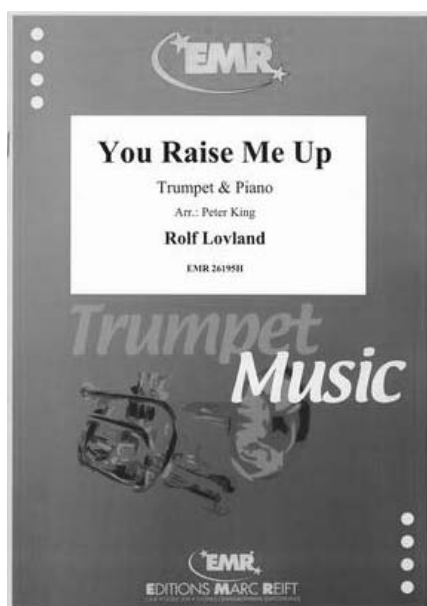
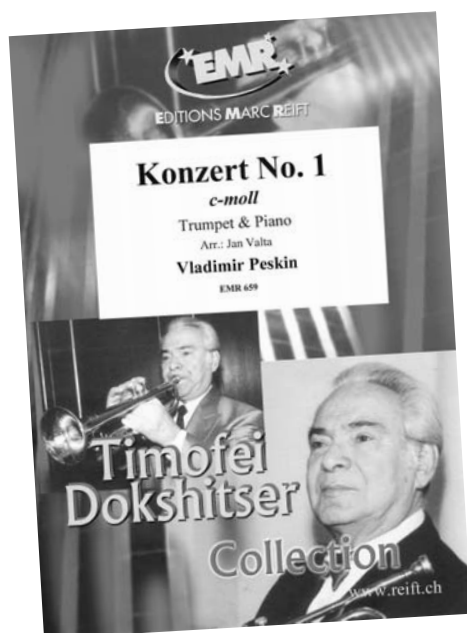

Discover all our scores for Trumpet-Cornet

Entdecken Sie alle unsere Noten für Trompete-Kornett

Découvrez toutes nos partitions pour Trompette-Cornet

**SCAN
ME** >



Use the filters to refine your search and find for example the style of your choice!

Nutzen Sie die Filter, um Ihre Suche zu verfeinern und zum Beispiel den Stil Ihrer Wahl zu finden!

Utilisez les filtres pour affiner votre recherche et trouver par exemple le style de votre choix!