

Aires Andaluces

Trumpet or Cornet (B^b + C) & Piano

Arr.: Michal Worek

Guillermo Gómez

EMR 97564

Des milliers d'enregistrements disponibles sur
Thousands of recordings available on
Tausende Aufnahmen verfügbar unter



TÉLÉCHARGEMENT : UN CLIC, UNE IMPRESSION – À VOUS DE JOUER !

Achetez, imprimez et jouez vos partitions en toute simplicité.

DOWNLOADING: ONE CLICK, ONE PRINT – AND YOU'RE READY TO PLAY!

Buy, print and play your sheet music with ease.

DOWNLOAD: EIN KLICK, EIN AUSDRUCK – UND SCHON KANN'S LOSGEHEN!

Kaufen, drucken und spielen Sie Ihre Noten ganz einfach.

WWW.REIFT.CH



EDITIONS MARC REIFT

Route du Golf 150 • CH-3963 Crans-Montana (Switzerland)
Tel. +41 (0) 27 483 12 00 • E-Mail : info@reift.ch • www.reift.ch

Aires Andaluces

Guillermo Gómez

English:

Aires Andaluces, composed by Guillermo Gómez and arranged by Michal Worek, transports the listener to the heart of Andalusia, a region emblematic of Spanish music. It draws inspiration from the passionate rhythms and captivating melodies of Andalusian folklore, blending liveliness with lyricism. The composer deploys a rich expressive palette, alternating between lively passages and more contemplative moments, revealing the warmth and emotional intensity of Spanish musical tradition. Michal Worek's arrangement faithfully preserves the original spirit while providing clarity and fluidity that allow every musical detail to shine. The work captivates with its rhythmic variety, dynamic contrasts, and vibrant character. It offers a sonic journey where elegance, energy, and expressiveness intertwine. *Aires Andaluces* invites the listener to feel the passion and soul of Andalusia in every note and motif.

Français:

Aires Andaluces, composé par Guillermo Gómez et arrangé par Michal Worek, est une œuvre qui transporte l'auditeur au cœur de l'Andalousie, région emblématique de la musique espagnole. Elle puise son inspiration dans les rythmes passionnés et les mélodies envoûtantes du folklore andalou, mêlant vivacité et lyrisme. Le compositeur y déploie une palette expressive riche, alternant passages dansants et moments plus contemplatifs, qui révèlent toute la chaleur et l'intensité émotionnelle de la tradition musicale espagnole. L'arrangement de Michal Worek respecte fidèlement l'esprit original tout en apportant une clarté et une fluidité qui permettent à chaque détail musical de se révéler. L'œuvre séduit par sa variété rythmique, ses contrastes dynamiques et son caractère vibrant. Elle offre un voyage sonore où se mêlent élégance, énergie et expressivité. *Aires Andaluces* invite l'auditeur à ressentir la passion et l'âme de l'Andalousie à travers chaque note et chaque motif.

Deutsch:

Aires Andaluces, komponiert von Guillermo Gómez und arrangiert von Michal Worek, entführt den Zuhörer in das Herz Andalusiens, einer Region, die für spanische Musik steht. Die Komposition schöpft ihre Inspiration aus den leidenschaftlichen Rhythmen und fesselnden Melodien der andalusischen Folklore und verbindet Lebendigkeit mit Lyrik. Der Komponist nutzt eine reiche Ausdruckspalette, wechselt zwischen lebhaften Passagen und nachdenklichen Momenten und zeigt die Wärme und emotionale Intensität der spanischen Musiktradition. Das Arrangement von Michal Worek bewahrt den ursprünglichen Geist treu und verleiht gleichzeitig Klarheit und Fluss, sodass jedes musikalische Detail zur Geltung kommt. Das Werk besticht durch rhythmische Vielfalt, dynamische Kontraste und lebendigen Charakter. Es bietet eine klangliche Reise, in der Eleganz, Energie und Ausdruckskraft miteinander verschmelzen. *Aires Andaluces* lädt den Zuhörer ein, die Leidenschaft und die Seele Andalusiens in jeder Note und jedem Motiv zu spüren.



EDITIONS MARC REIFT

Route du Golf 150 • CH-3963 Crans-Montana (Switzerland)

Tel. +41 (0) 27 483 12 00 • E-Mail : info@reift.ch • www.reift.ch

Photocopying
is illegal!

Aires Andaluces

Guillermo Gómez

Arr.: Michal Worek

Allegro ♩ = 144 **Lento** ♩ = 72 **Allegro** ♩ = 144 **Lento** ♩ = 72

B♭ Trumpet or Cornet

Piano

ff **mf** **ff**

A **Presto** ♩ = 184

mf **mf** **f** **f**

7 13 19

EMR 97564

© COPYRIGHT BY EDITIONS MARC REIFT CH-3963 CRANS-MONTANA (SWITZERLAND)
ALL RIGHTS RESERVED - INTERNATIONAL COPYRIGHT SECURED

www.reift.ch

26 **B** *Meno mosso* ♩ = 138

Musical score for measures 26-31. The piece is in 3/4 time, marked *Meno mosso* with a tempo of ♩ = 138. The score consists of three staves: a single treble clef staff at the top, and a grand staff (treble and bass clefs) below. The top staff begins with a piano (*p*) dynamic and features a melodic line with eighth notes. The grand staff begins with a piano (*p*) dynamic and features a bass line with eighth notes and a left-hand accompaniment of chords. A crescendo hairpin spans from measure 26 to 31, leading to a mezzo-piano (*mp*) dynamic. A triplet of eighth notes is marked with a '3' in measure 31.

32

Musical score for measures 32-37. The score continues with the same three-staff layout. The top staff has a mezzo-forte (*mf*) dynamic. The grand staff has a mezzo-forte (*mf*) dynamic. A crescendo hairpin spans from measure 32 to 37. Triplet markings with '3' are present in measures 32, 35, and 37.

38

Musical score for measures 38-43. Section **C** begins. The top staff has a fortissimo (*ff*) dynamic. The grand staff has a fortissimo (*ff*) dynamic. The music is characterized by dense textures, including sixteenth-note runs in the top staff and complex chordal structures in the grand staff.

44

Musical score for measures 44-48. Section **D** begins. The top staff has a mezzo-forte *subito* (*mf subito*) dynamic. The grand staff has a mezzo-forte (*mf*) dynamic. The music features a melodic line with slurs in the top staff and a bass line with chords in the grand staff.

49

Musical score for measures 49-54. The top staff has a fortissimo (*f*) dynamic. The grand staff has a fortissimo (*f*) dynamic. The music continues with a melodic line in the top staff and a bass line with chords in the grand staff. Pedal markings (*Ped.*) are present in measures 52 and 54.

Collection Trumpet-Cornet

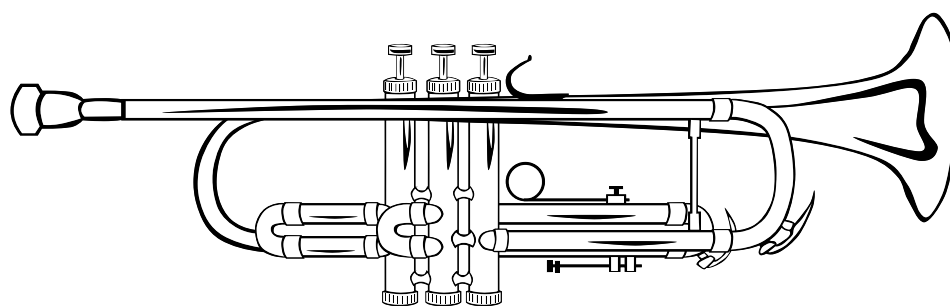
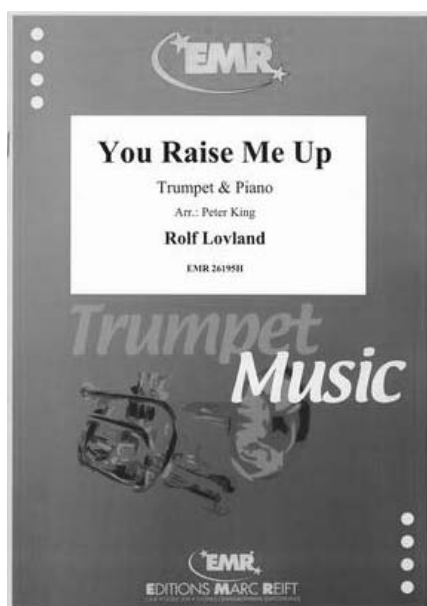
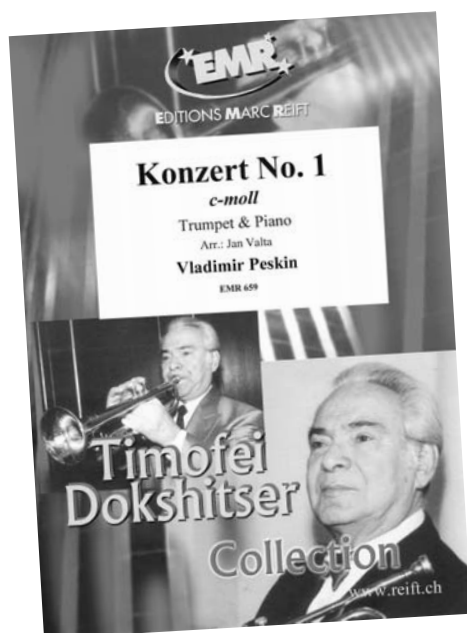

Discover all our scores for Trumpet-Cornet

Entdecken Sie alle unsere Noten für Trompete-Kornett

Découvrez toutes nos partitions pour Trompette-Cornet

**SCAN
ME >**



Use the filters to refine your search and find for example the style of your choice!

Nutzen Sie die Filter, um Ihre Suche zu verfeinern und zum Beispiel den Stil Ihrer Wahl zu finden!

Utilisez les filtres pour affiner votre recherche et trouver par exemple le style de votre choix!